

## SECTION 1D

# ENGINE COOLING

**CAUTION:** Disconnect the negative battery cable before removing or installing any electrical unit or when a tool or equipment could easily come in contact with exposed electrical terminals. Disconnecting this cable will help prevent personal injury and damage to the vehicle. The ignition must also be in LOCK unless otherwise noted.

## TABLE OF CONTENTS

<p><b>Specifications</b> ..... 1D-1</p> <p>    Capacity ..... 1D-1</p> <p>    Fastener Tightening Specifications ..... 1D-2</p> <p><b>Special Tools</b> ..... 1D-2</p> <p>    Special Tools Table ..... 1D-2</p> <p><b>Diagnosis</b> ..... 1D-3</p> <p>    Thermostat Test ..... 1D-3</p> <p>    Surge Tank Cap Test ..... 1D-3</p> <p>    Cooling System Diagnosis ..... 1D-4</p> <p><b>Component Locator</b> ..... 1D-5</p> <p>    Radiator/Fan ..... 1D-5</p> <p>    Coolant Pump/Thermostat (DOHC) ..... 1D-6</p> <p>    Coolant Pump/Thermostat (SOHC) ..... 1D-7</p> <p><b>Maintenance and Repair</b> ..... 1D-8</p> <p>    On-Vehicle Service ..... 1D-8</p> <p>    Draining and Refilling the Cooling System ..... 1D-8</p> <p>    Thermostat ..... 1D-9</p>	<p>    Coolant Pump ..... 1D-12</p> <p>    Electric Cooling Fan - Main or Auxiliary ..... 1D-15</p> <p>    Surge Tank ..... 1D-17</p> <p>    Radiator ..... 1D-18</p> <p>    Coolant Temperature Sensor ..... 1D-21</p> <p><b>General Description and System</b></p> <p>    <b>Operation</b> ..... 1D-23</p> <p>    General Description ..... 1D-23</p> <p>    Radiator ..... 1D-23</p> <p>    Surge Tank ..... 1D-23</p> <p>    Coolant Pump ..... 1D-23</p> <p>    Thermostat ..... 1D-23</p> <p>    Electric Cooling Fan ..... 1D-24</p> <p>    Coolant Temperature Sensor ..... 1D-24</p> <p>    Engine Coolant Temperature Sensor ..... 1D-24</p> <p>    Engine Block Heater ..... 1D-24</p>
--	---

## SPECIFICATIONS

### CAPACITY

Application	Description
Coolant in the Cooling System (DOHC MPFI System)	7.0L (1.86 gal)
Coolant in the Cooling System (SOHC MPFI System)	7.0L (1.86 gal)

## FASTENER TIGHTENING SPECIFICATIONS

Application	N•m	Lb•Ft	Lb•In
Coolant Pump Mounting Bolts	20	15	-
Coolant Temperature Sensor	20	15	-
Fan Assembly Mounting Bolts	4	-	35
Fan Motor Nut	3.2	-	28
Fan Motor Retaining Screws	4	-	35
Radiator Retaining Bolts	4	-	35
Surge Tank Attaching Bolt	4	-	35
Thermostat Housing Mounting Bolt	15	11	-
Transaxle Fluid Cooler Pipe Bolt	22	16	-

## SPECIAL TOOLS

### SPECIAL TOOLS TABLE

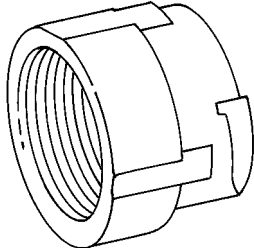
 <p>A102D020</p>	<p><b>KM-471 Adapter</b></p>
--	----------------------------------

## DIAGNOSIS

### THERMOSTAT TEST

1. Remove the thermostat from the vehicle. Refer to "Thermostat" in this section.
2. Make sure the valve spring is tight when the thermo-stat is fully closed. If the spring is not tight, replace the thermostat.
3. Suspend the thermostat and a thermometer in a pan of 50/50 mixture of ethylene glycol and water. Do not let the thermostat or the thermometer rest on the bottom of the pan because the uneven concentration of heat on the bottom could result in inaccurate temperature measurements.
4. Heat the pan on a burner.
5. Use the thermometer to measure the temperature of the heated solution.
6. The thermostat should begin to open at 87°C (189°F) and it should be fully open at 102°C (226°F). If it does not open at these temperatures, replace the thermo-stat.

### SURGE TANK CAP TEST

#### Tools Required

KM-471 Adapter

The surge tank cap maintains proper pressure, protects the system from high pressure by opening a pressure valve, and protects the coolant hoses from collapsing because of a vacuum.

1. Wash any sludge from the surge tank cap and the valve seat of the vacuum pressure valve for the surge tank cap.

2. Check for any damage or deformity to the vacuum pressure valve for the surge tank cap. If any damage or deformity is found, replace the cap.
3. Install a suitable cooling system pressure tester to the cap using the adapter KM-471.
4. Pull the vacuum pressure valve open. If the surge tank cap does not seal properly, replace the surge tank cap.
5. Pressurize the cap to 90 to 120 kPa (13 to 17 psi).
6. Wait 10 seconds and check the pressure held by the tank cap tester.

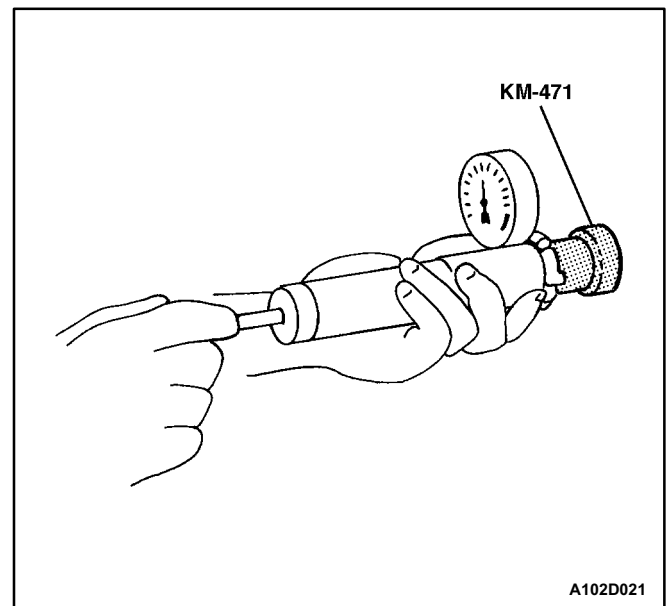

A102D021

7. If the pressure held by the cooling system pressure tester falls below 80 kPa (11.6 psi), replace the surge tank cap.

**COOLING SYSTEM DIAGNOSIS****Engine Overheats**

<b>Checks</b>	<b>Action</b>
Check for a loss of the coolant.	Add the coolant.
Check for a weak coolant solution.	Confirm that the coolant solution is a 50/50 mixture of ethylene glycol and water.
Check the front of the radiator for any dirt, any leaves, or any insects.	Clean the front of the radiator.
Check for leakage from the hoses, the coolant pump, the heater, the thermostat housing, the radiator, the core plugs, or the head gasket.	Replace any damaged components.
Check for a faulty thermostat.	Replace a damaged thermostat.
Check for retarded ignition timing.	Perform an ECM code diagnosis. Confirm the integrity of the timing belt.
Check for an improperly operating electric cooling fan.	Replace the electric cooling fan.
Check for radiator hoses that are plugged or rotted.	Replace any damaged radiator hoses.
Check for a faulty water pump.	Replace a faulty water pump.
Check for a faulty surge tank cap.	Replace a faulty surge tank cap.
Check for a cylinder head or an engine block that is cracked or plugged.	Repair the damaged cylinder head or the damaged engine block.

**Loss of Coolant**

<b>Checks</b>	<b>Action</b>
Check for a leak in the radiator.	Replace a damaged radiator.
Check for a leak in the following locations: <ul style="list-style-type: none"> <li>● Surge tank.</li> <li>● Hose.</li> </ul>	Replace the following parts, as needed: <ul style="list-style-type: none"> <li>● Surge tank.</li> <li>● Hose.</li> </ul>
Check for loose or damaged radiator hoses, heater hoses, and connections.	Reseat the hoses. Replace the hoses or the clamps.
Check for leaks in the coolant pump seal.	Replace the coolant pump seal.
Check for leaks in the coolant pump gasket.	Replace the coolant pump gasket.
Check for an improper cylinder head torque.	Tighten the cylinder head bolts to specifications. Replace the cylinder head gasket, if needed.
Check for leaks in the following locations: <ul style="list-style-type: none"> <li>● Intake manifold.</li> <li>● Cylinder head gasket.</li> <li>● Cylinder block plug.</li> <li>● Heater core.</li> <li>● Radiator drain plug.</li> </ul>	Repair or replace any components, as needed, to correct the leak.

**Engine Fails to Reach Normal Operating Temperature or Cool Air from the Heater**

<b>Checks</b>	<b>Action</b>
Check to determine if the thermostat is stuck open or is the wrong type of thermostat.	Install a new thermostat of the correct type and heat range.
Check the coolant level to determine if it is below the MIN mark on the surge tank.	Add sufficient coolant to raise the fluid to the specified mark on the surge tank.

# COMPONENT LOCATOR

## RADIATOR/FAN

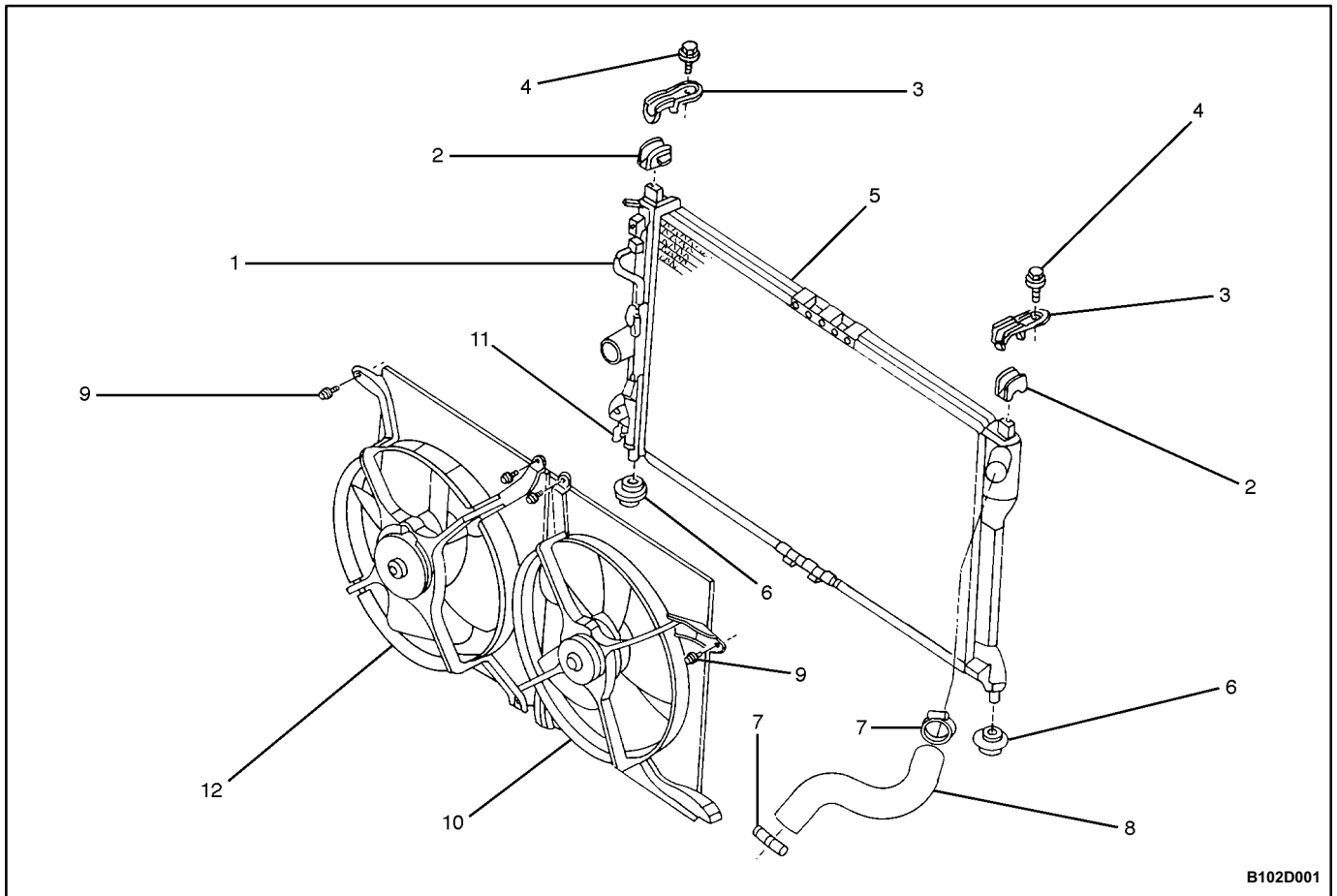

B102D001

- |  |                               |
|--|-------------------------------|
| 1 Transaxle Fluid Cooler Pipe Holder<br>(Automatic Transaxle Only) | 7 Spring Clamp                |
| 2 Upper Radiator Bumper  | 8 Upper Radiator Hose         |
| 3 Radiator Bracket   | 9 Fan Assembly Mounting Bolts |
| 4 Radiator Retaining Bolts   | 10 Auxiliary Cooling Fan      |
| 5 Radiator   | 11 Drain Plug                 |
| 6 Radiator Bumper  | 12 Main Cooling Fan           |

## COOLANT PUMP/THERMOSTAT (DOHC)

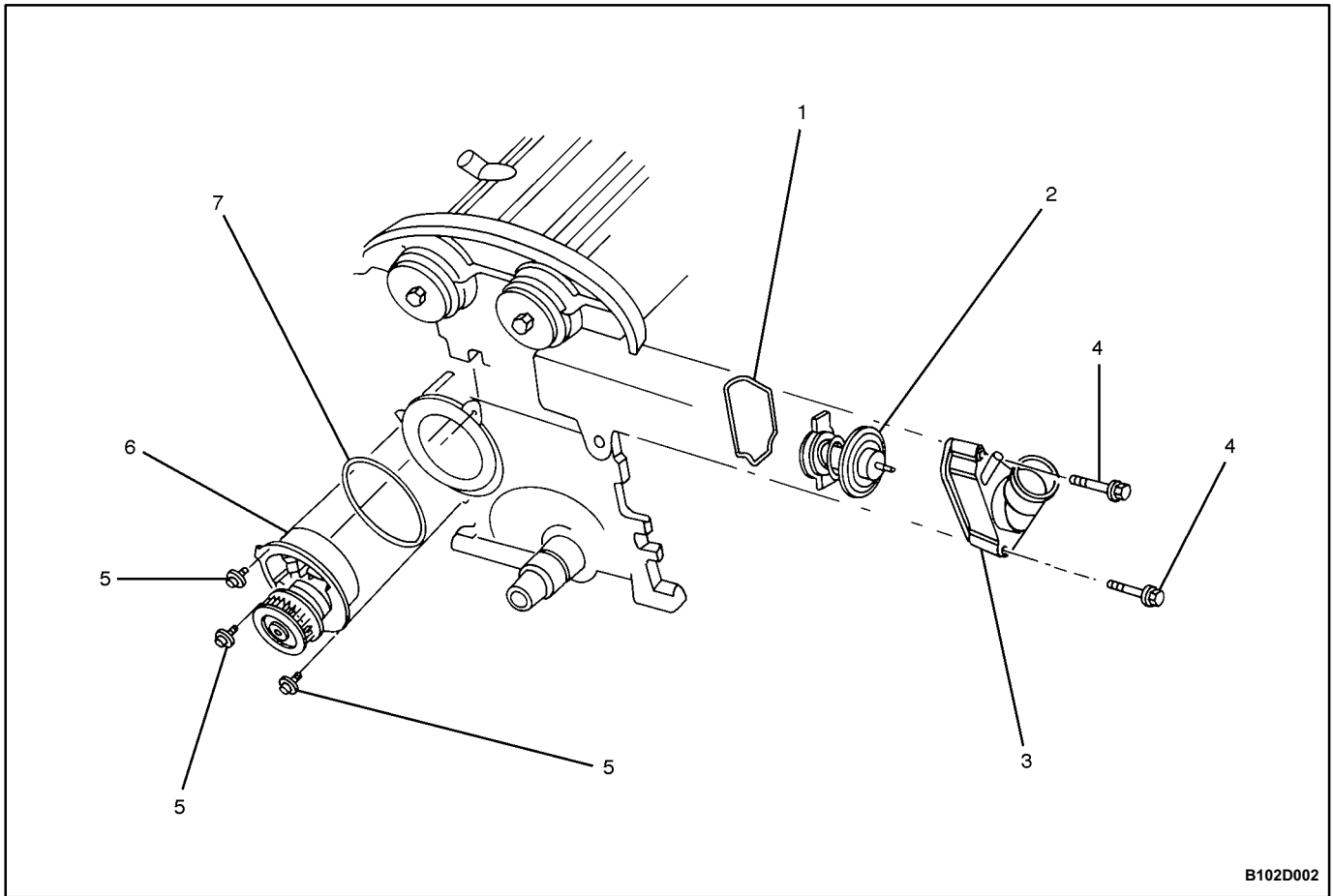

1 ORing Seal

2 Thermostat

3 Thermostat Housing

4 Thermostat Housing Mounting Bolt

5 Coolant Pump Mounting Bolt

6 Coolant Pump

7 Ring Seal

B102D002

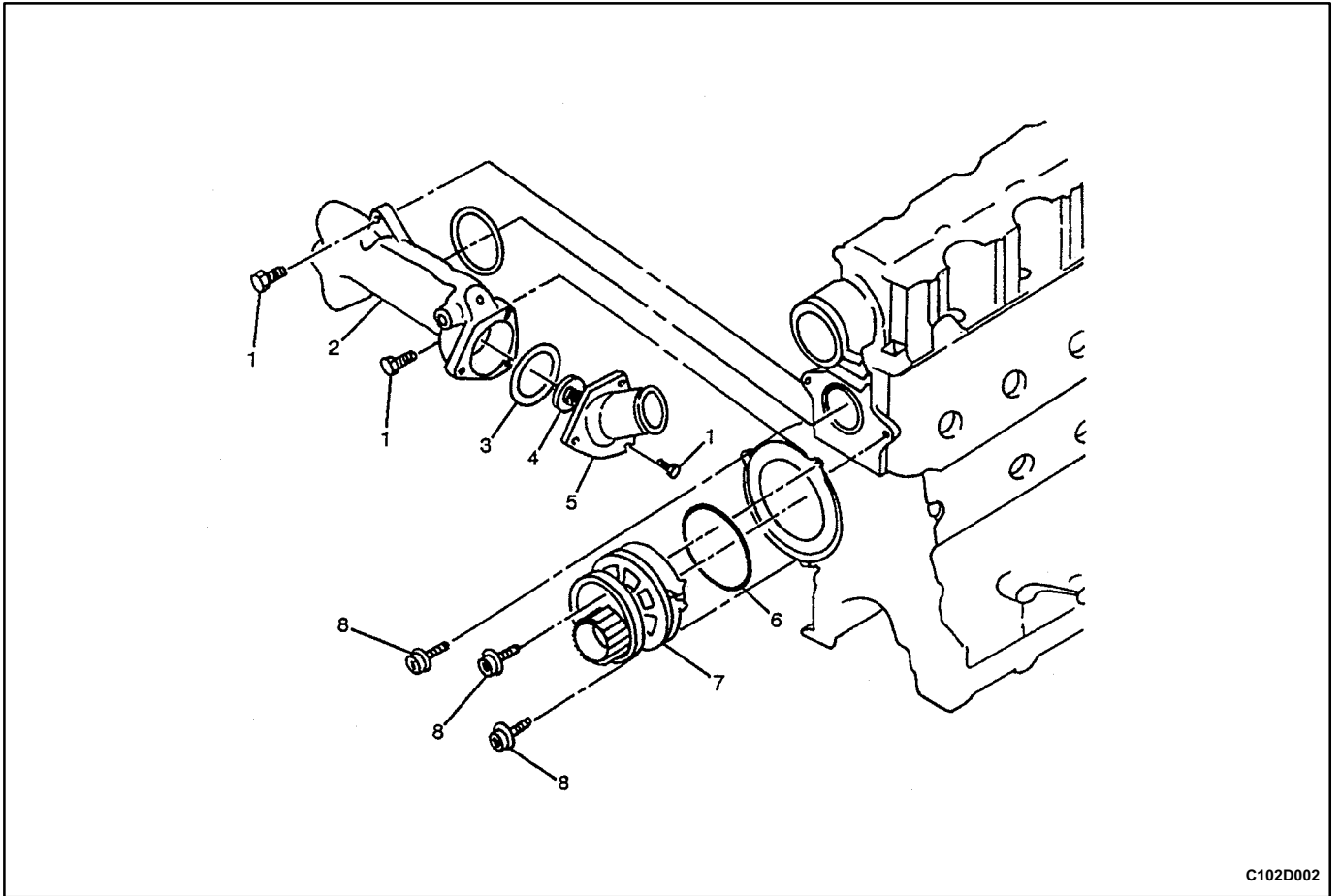
**COOLANT PUMP/THERMOSTAT (SOHC)**

C102D002

- 1 Thermostat Housing Mounting Bolt
- 2 Coolant Housing
- 3 Seal Ring
- 4 Thermostat

- 5 Thermostat Housing
- 6 ORing
- 7 Coolant Pump
- 8 Coolant Pump Mounting Bolts

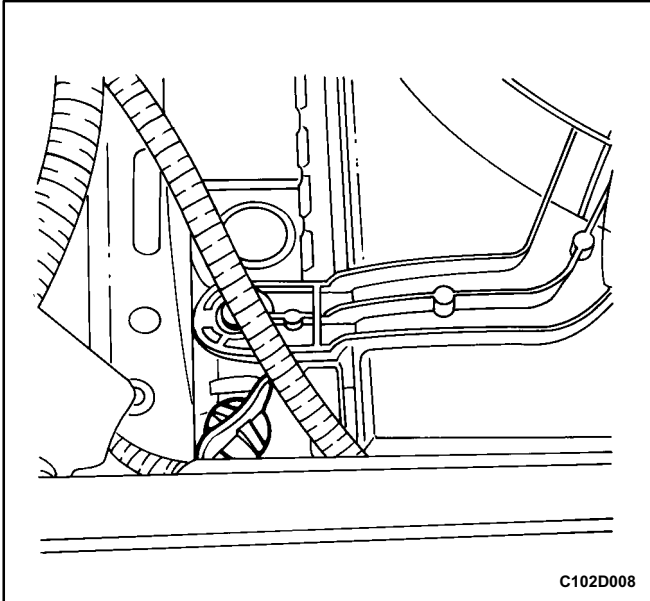

## MAINTENANCE AND REPAIR

### ON-VEHICLE SERVICE

#### DRAINING AND REFILLING THE COOLING SYSTEM

**Caution:** Do not remove the surge tank cap while the engine and the radiator are hot. Scalding fluid and steam may be blown out under pressure.

1. Place a pan below the vehicle to catch the draining coolant.
2. Remove the surge tank cap.
3. Unplug the drain plug.

**Caution:** Dispose of the used coolant in a used coolant holding tank to be picked up with the used oil for disposal. Never pour the used coolant down the drain. Ethylene glycol antifreeze is an extremely toxic chemical. Disposing of it into the sewer system or the ground water can contaminate the local environment.

4. Catch the escaping fluid in a drain pan.
5. Remove all sludge and dirt from inside the surge tank. Refer to "Surge Tank" in this section.
6. Screw in the drain plug.
7. Add the clean water to the surge tank.
8. Fill the tank slowly so that the upper reservoir hose remains above the water line. This allows the air inside the cooling system to escape.
9. Start the engine.
10. Run the engine until the thermostat opens. You can tell the thermostat is open when both radiator hoses are hot to the touch.

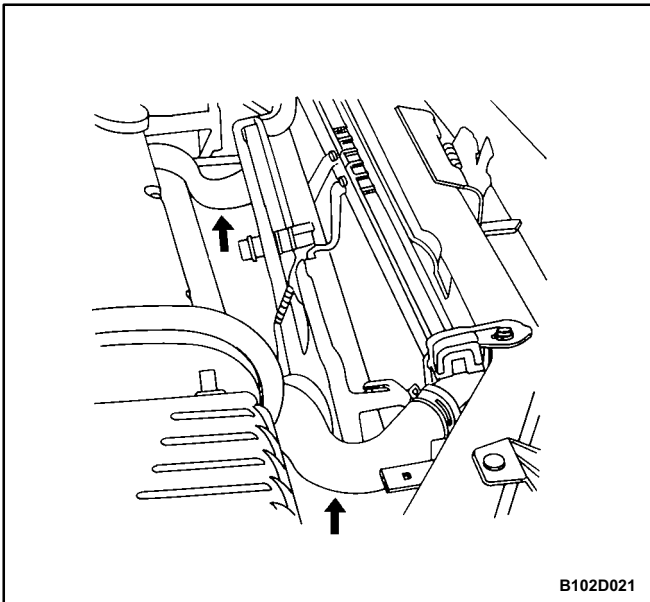



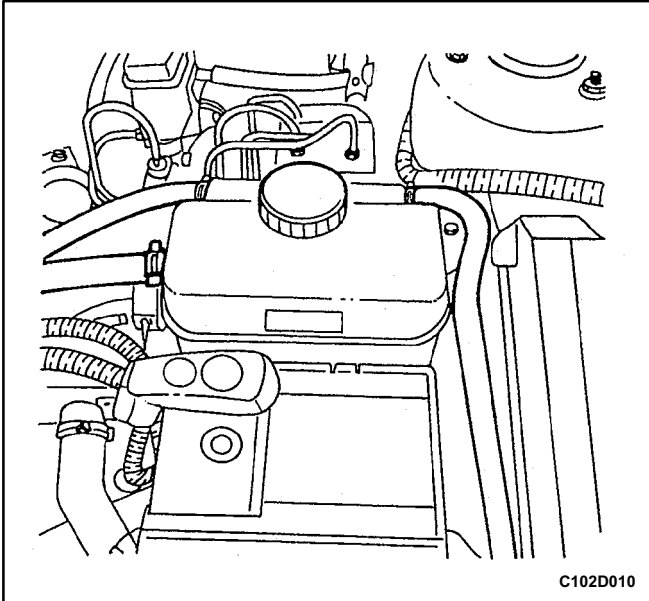

11. Stop the engine.
12. Repeat steps 1 through 9 until the drained water is clear and free of coolant and rust.

**Notice:** Never use an antifreeze mixture more concentrated than 60 percent antifreeze to 40 percent water. The solution freezing point increases above this concentration.

13. Fill the cooling system through the surge tank with a mixture of ethylene glycol antifreeze and water. The mixture must be at least 50 percent antifreeze, but not more than 60 percent antifreeze.
14. Fill the surge tank to the specified MAX fill mark on the outside of the tank.

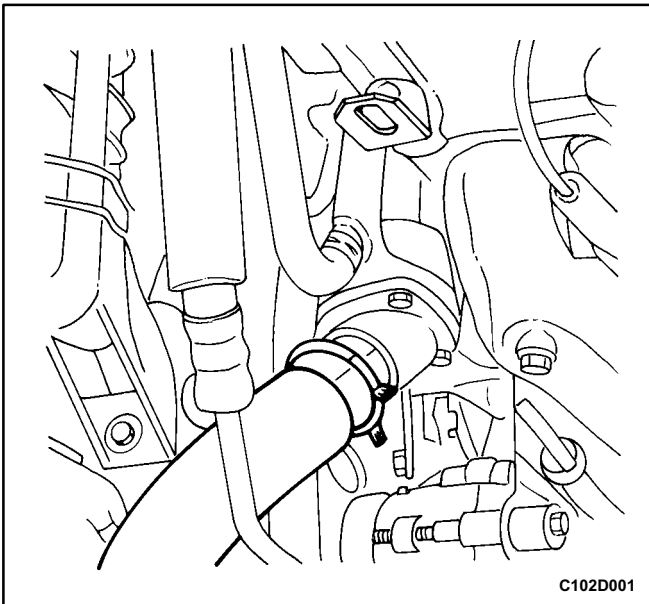

## THERMOSTAT

### SOHC

#### Removal Procedure

**Caution:** To prevent personal injury, do not remove the surge tank cap while the engine and the radiator are hot because the heat causes the system to re-main under pressure. Scalding fluid and steam may be blown out under pressure.

1. Drain the coolant. Refer to "Draining and Refilling the Cooling System" in this section.
2. Loosen the hose clamp on the upper radiator hose at the thermostat housing.
3. Disconnect the upper radiator hose from the thermostat housing.
4. Remove the mounting bolts that hold the thermostat housing to the coolant housing.
5. Remove the thermostat housing from the coolant housing.
6. Remove the thermostat from its recess in the coolant housing.
7. Inspect the valve seat for foreign matter that could prevent the valve from seating properly.
8. Inspect the thermostat for proper operation. Refer to "Thermostat Test" in this section.
9. Clean the thermostat housing and the coolant housing mating surfaces.

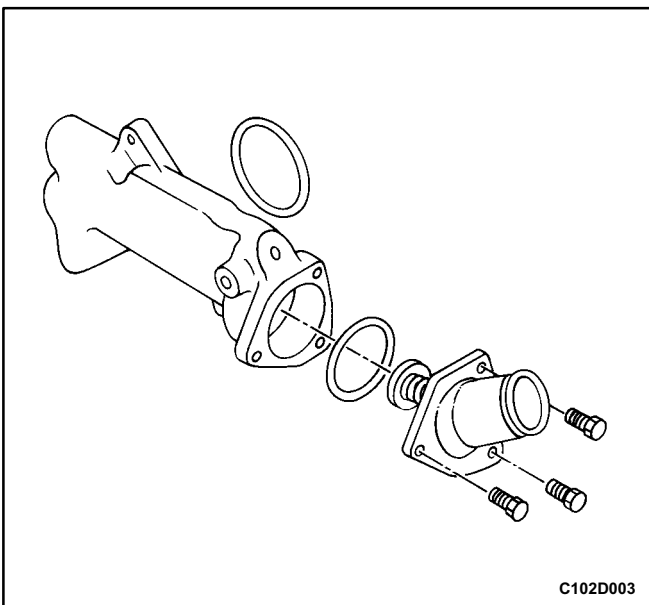

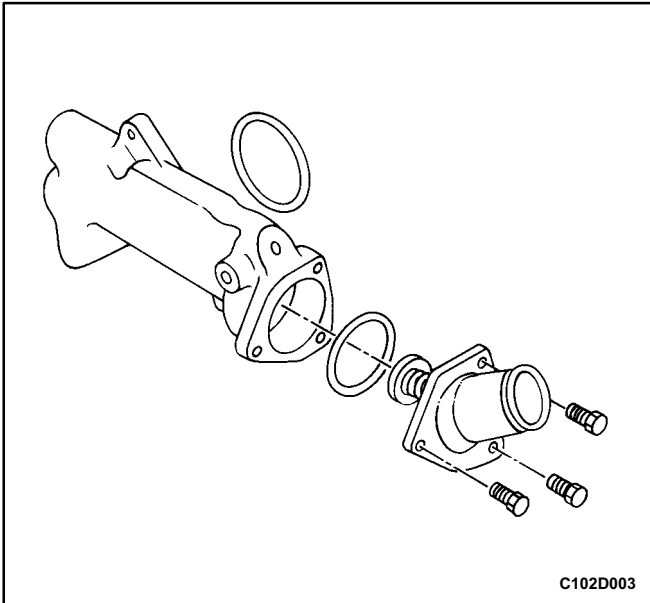

## Installation Procedure

1. Install the thermostat into the cylinder head recess.
2. Install the thermostat housing.
3. Secure the thermostat housing to the cylinder head with the mounting bolts.

### Tighten

Tighten the thermostat housing mounting bolts to 15 N•m (11 lb•ft).

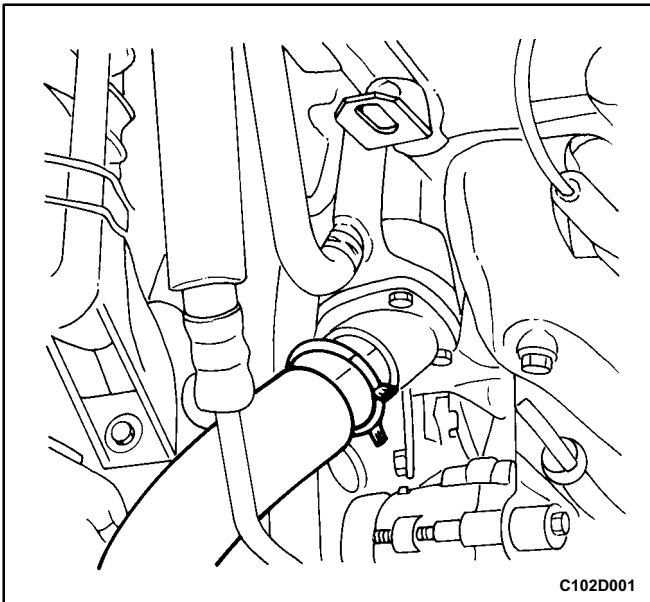

4. Connect the upper radiator hose to the thermostat housing.
5. Secure the upper radiator hose to the thermostat housing with a hose clamp.
6. Refill the engine cooling system. Refer to "Draining and Refilling the Cooling System" in this section.

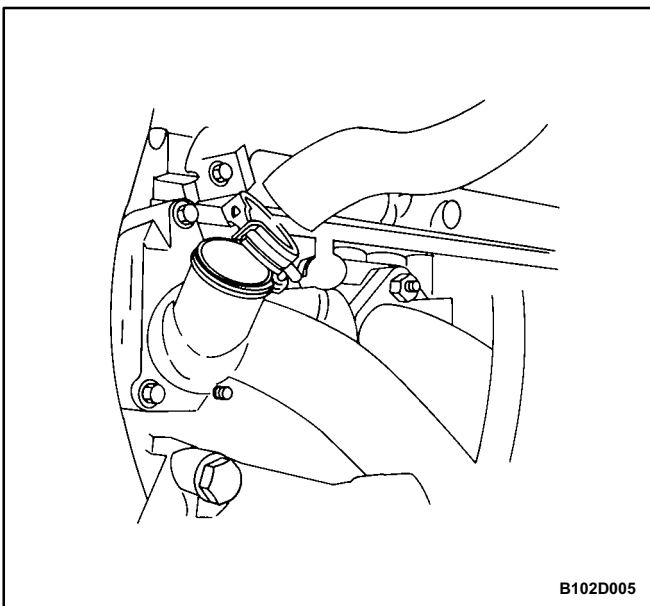

## DOHC

### Removal Procedure

**Caution:** To prevent personal injury, do not remove the surge tank cap while the engine and the radiator are hot because the heat causes the system to re-main under pressure. Scalding fluid and steam may be blown out under pressure.

1. Drain the coolant. Refer to "Draining and Refilling the Cooling System" in this section.
2. Loosen the hose clamp on the upper radiator hose at the thermostat housing.
3. Disconnect the upper radiator hose from the thermostat housing.

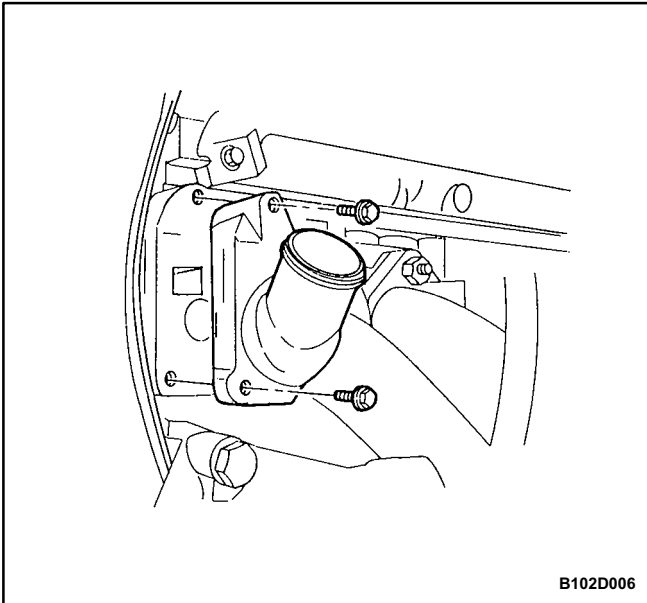

B102D006

4. Remove the mounting bolts that hold the thermostat housing to the cylinder head.
5. Remove the thermostat housing from the cylinder head.

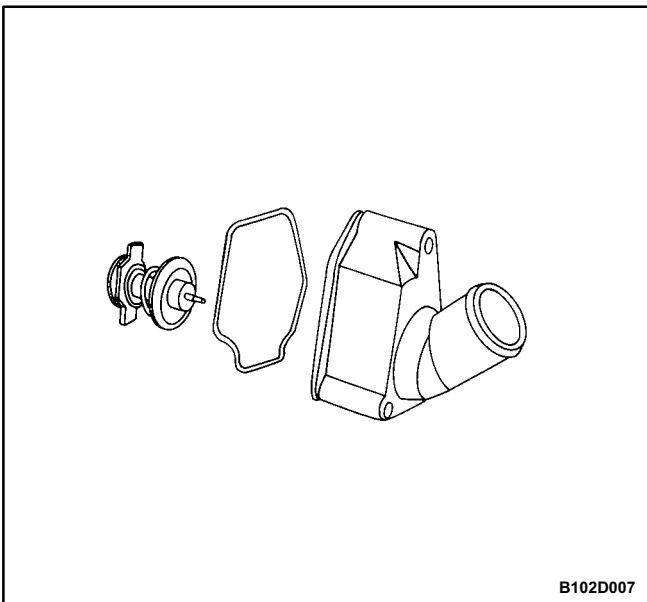

B102D007

6. Remove the O-ring seal from the thermostat housing.
7. Remove the thermostat from the thermostat housing by pressing the thermostat mounting flange downward and then rotating the flange clockwise.
8. Inspect the valve seat for foreign matter that could prevent the valve from sealing properly.
9. Inspect the thermostat for proper operation. Refer to "Thermostat Test" in this section.
10. Clean the thermostat housing and the cylinder head mating surfaces.

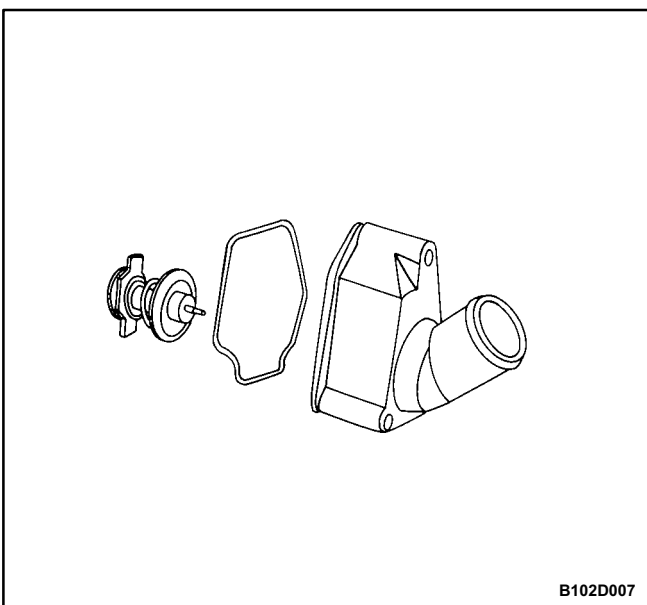

B102D007

### Installation Procedure

1. Install the thermostat into the thermostat housing by pressing the thermostat mounting flange downward and then rotating the flange counterclockwise. Rotate the thermostat mounting flange until it is seated in the thermostat housing recesses.
2. Coat the sealing surface of a new O-ring seal with Lubriplate®.
3. Install a new O-ring seal into the recess in the thermostat housing.

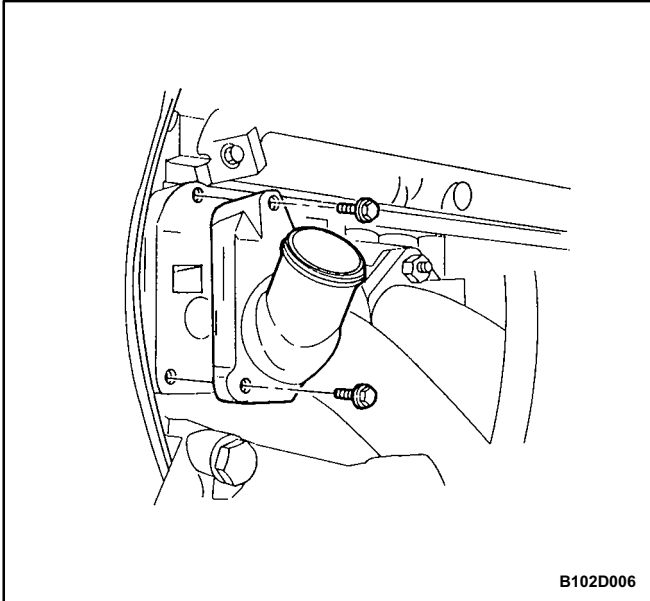

4. Install the thermostat housing to the cylinder head.
5. Secure the thermostat housing to the cylinder head with the mounting bolts.

### Tighten

Tighten the thermostat housing mounting bolts to 15 N•m (11 lb•ft).

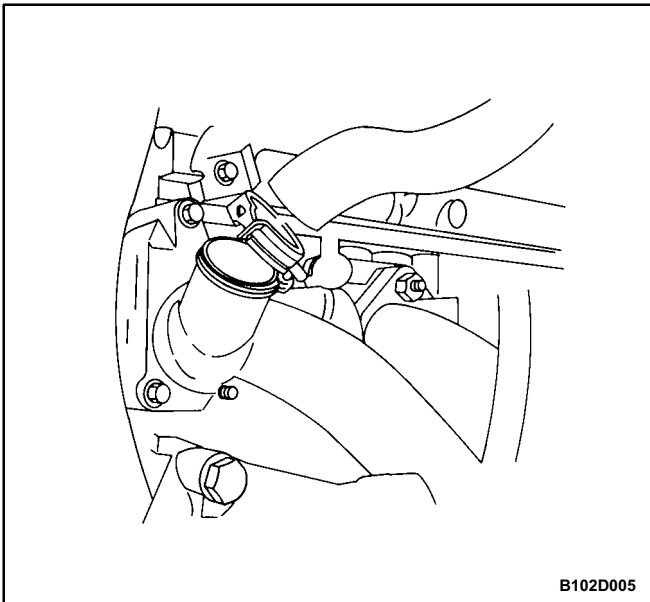

6. Connect the upper radiator hose to the thermostat housing.
7. Secure the upper radiator hose to the thermostat housing with a hose clamp.
8. Refill the engine cooling system. Refer to "Draining and Refilling the Cooling System" in this section.

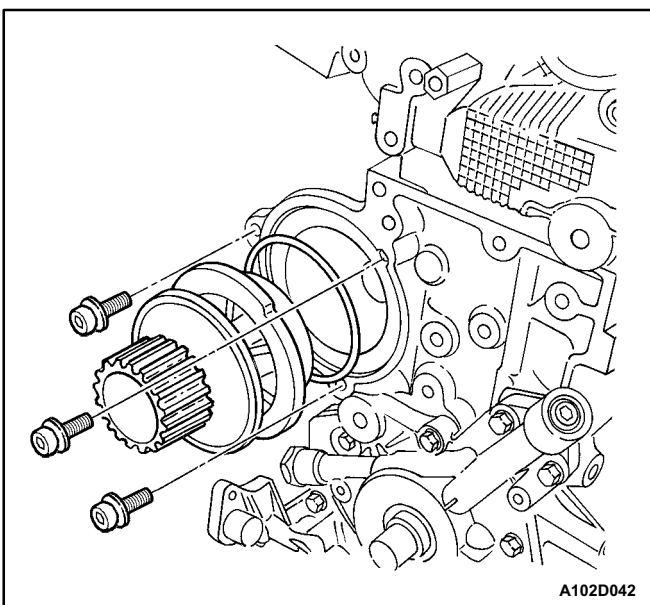

## COOLANT PUMP

### SOHC

#### Removal Procedure

1. Drain the engine cooling system to a level below the thermostat housing. Refer to "Draining and Refilling the Cooling System" in this section.
2. Remove the timing belt. Refer to *Section 1B, SOHC Engine Mechanical*.
3. Remove the coolant pump mounting bolts.
4. Remove the coolant pump from the engine block.
5. Remove the ring seal from the coolant pump.

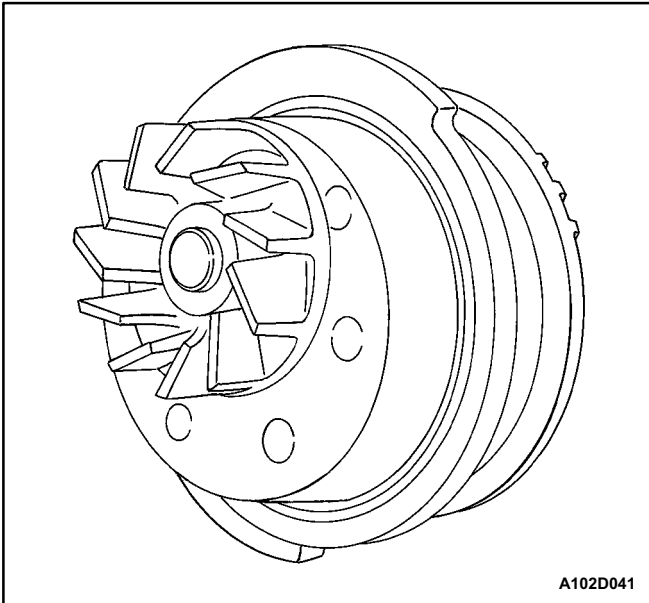

### Inspection and Cleaning Procedure

1. Inspect the coolant pump body for cracks and leaks.
2. Inspect the coolant pump bearing for play or abnormal noise.
3. Inspect the coolant pump pulley for excessive wear. If the coolant pump is defective, replace the coolant pump as a unit.
4. Clean the mating surfaces of the coolant pump and the engine block.

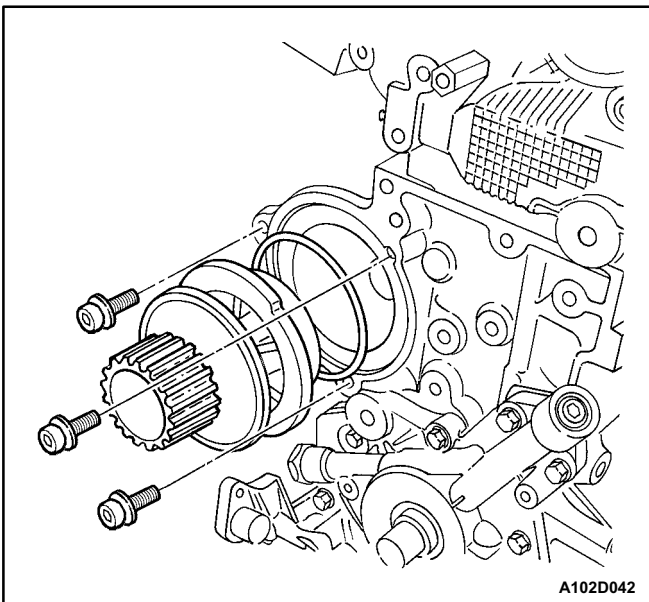

### Installation Procedure

1. Install a new ring seal to the coolant pump.
2. Coat the sealing surface of the ring seal with Lubri-plate®.
3. Install the coolant pump to the engine block.
4. Secure the coolant pump to the engine block with the mounting bolts.

### Tighten

Tighten the coolant pump mounting bolts to 20 N•m (15 lbft).

5. Install the timing belt. Refer to *Section 1B, SOHC Engine Mechanical*.
6. Refill the engine cooling system. Refer to "Draining and Refilling the Cooling System" in this section.

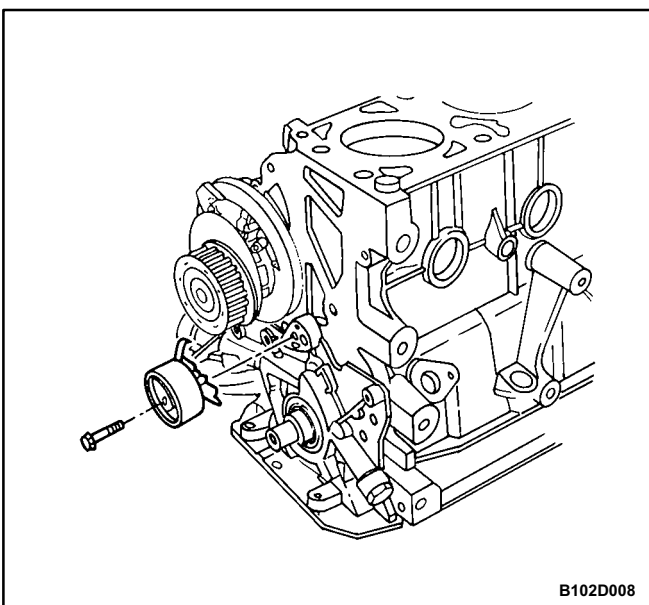

### DOHC

#### Removal Procedure

1. Drain the engine cooling system to a level below the thermostat housing. Refer to "Draining and Refilling the Cooling System" in this section.
2. Remove the timing belt. Refer to *Section 1C, DOHC Engine Mechanical*.
3. Remove the timing belt tension roller retaining bolt.
4. Remove the timing belt tension roller.

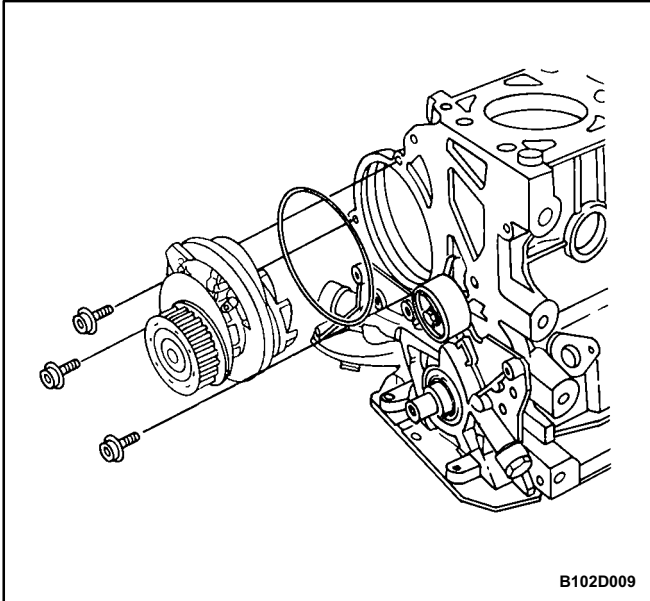

5. Remove the coolant pump mounting bolts.
6. Remove the coolant pump from the engine block.
7. Remove the ring seal from the coolant pump.

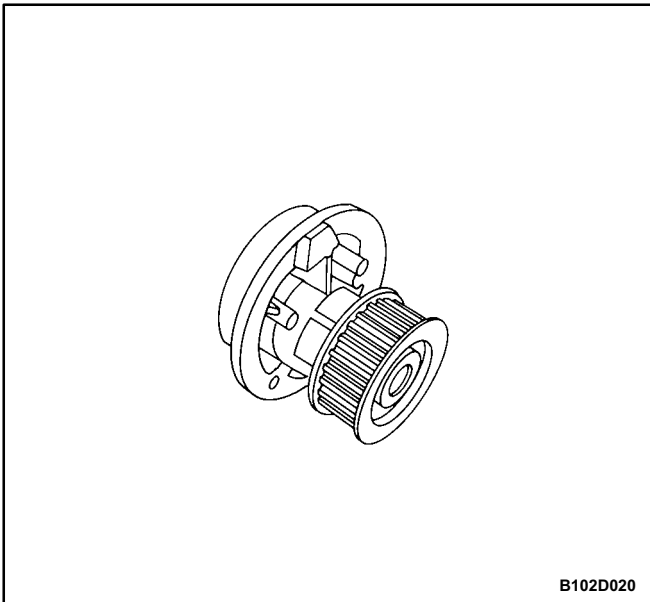

## Inspection Cleaning Procedure

1. Inspect the coolant pump body for cracks and leaks.
2. Inspect the coolant pump bearing for play or abnormal noise.
3. Inspect the coolant pump pulley for excessive wear. If the coolant pump is defective, replace the coolant pump as a unit.
4. Clean the mating surfaces of the coolant pump and the engine block.

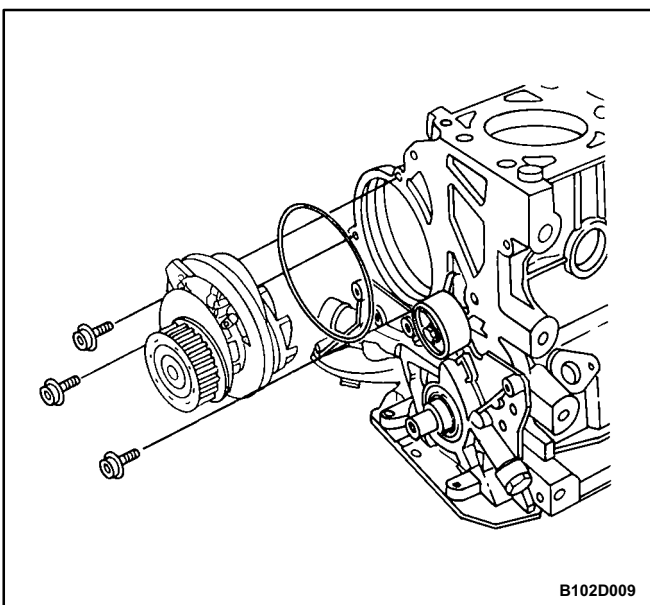

## Installation Procedure

1. Install a new ring seal to the coolant pump.
2. Coat the sealing surface of the ring seal with Lubri-plate®.
3. Install the coolant pump to the engine block with the flange aligned with the recess of the rear timing belt cover.
4. Secure the coolant pump to the engine block with the mounting bolts.

## Tighten

Tighten the coolant pump mounting bolts to 20 N•m (15 lb•ft).

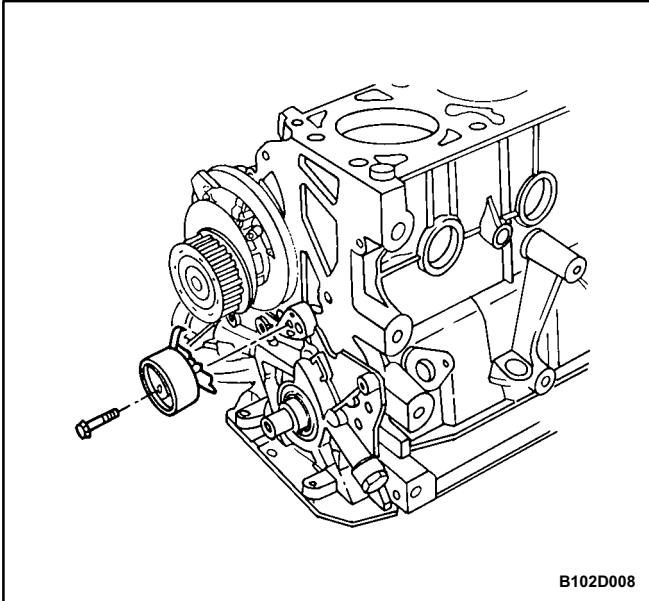

5. Install the timing belt tension roller to the oil pump with the flange inserted into the recess of the oil pump.
6. Install the timing belt tension roller bolt. Do not tighten the bolt at this time.
7. Install the timing belt. Refer to *Section 1C, DOHC Engine Mechanical*.
8. Refill the engine cooling system. Refer to "Draining and Refilling the Cooling System" in this section.

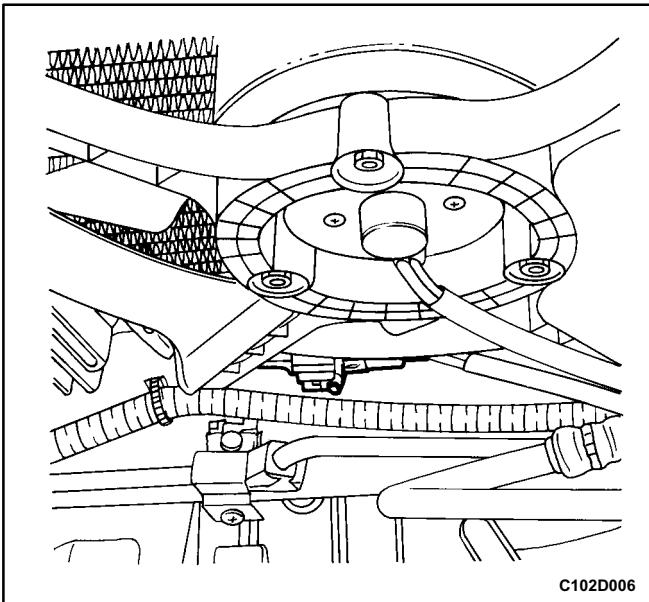

## ELECTRIC COOLING FAN - MAIN OR AUXILIARY

### Removal Procedure

1. Disconnect the negative battery cable.
  2. Disconnect the cooling fan electrical connector.
  3. Remove the fan shroud mounting bolts.
  4. Lift the fan shroud assembly upward, and remove the fan shroud assembly from the vehicle.
5. Remove the fan blade from the fan shroud assembly by removing the nut at the center of the fan hub.

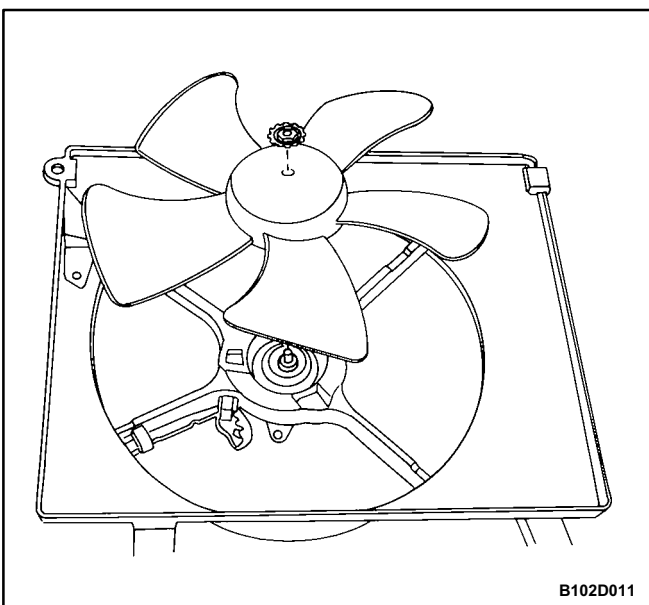

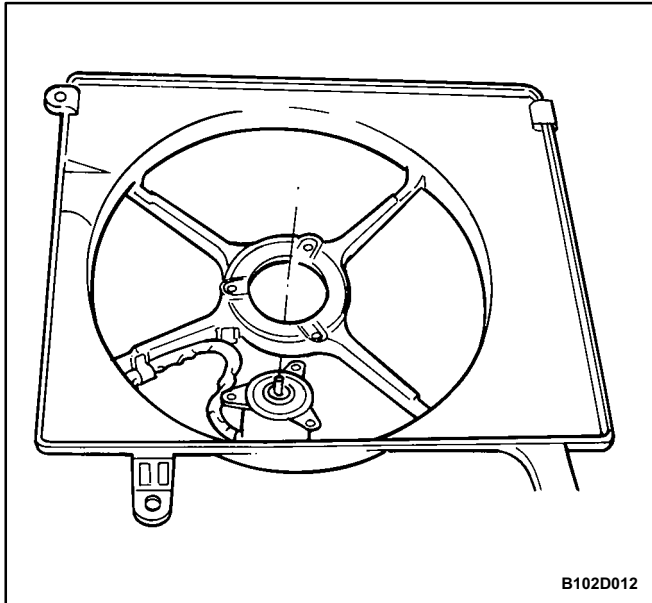

6. Remove the fan motor retaining screws.
7. Remove the fan motor from the shroud.

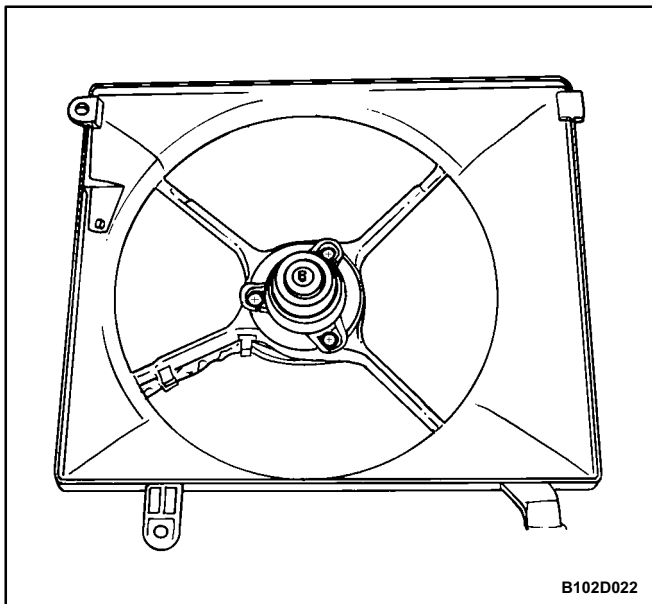

### Installation Procedure

**Caution:** If a fan blade is bent or damaged in any way, no attempt should be made to repair or reuse the damaged part. A bent or damaged fan assembly must be replaced with a new fan assembly. It is essential that fan assemblies remain in proper balance. A fan assembly that is not in proper balance can fail and fly apart during use, creating extreme danger. Proper balance cannot be assured on a fan assembly that has been bent or damaged.

1. Install the fan motor to the shroud.
2. Secure the motor to the shroud with the retaining screws.

#### Tighten

Tighten the fan motor retaining screws to 4 N•m (35 lb•in).

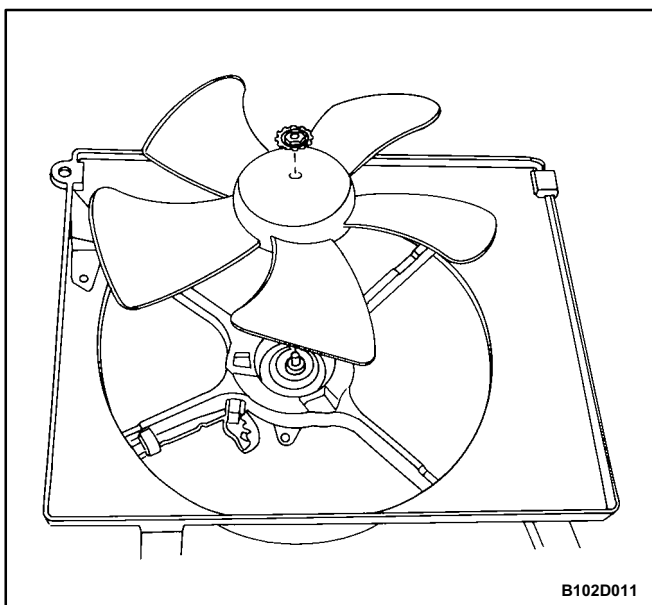

3. Install the fan to the fan shroud assembly with the single nut in the center of the fan hub.

#### Tighten

Tighten the fan motor nut to 3.2 N•m (28 lb•in).



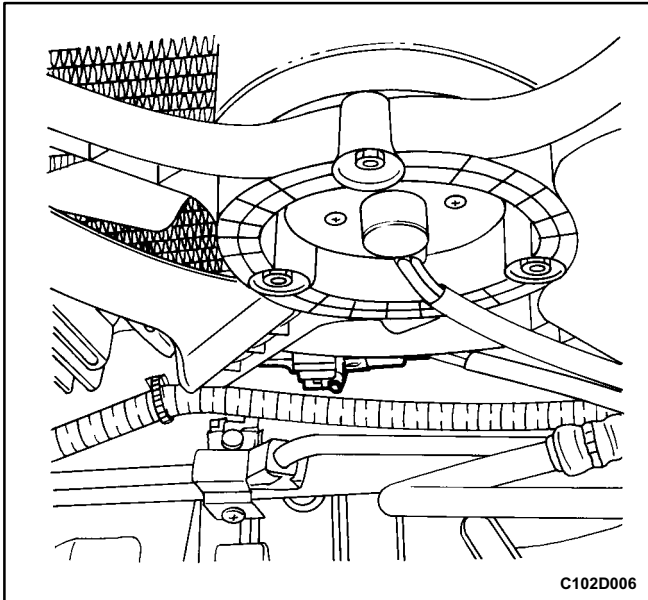

4. Install the fan shroud assembly to the radiator.

**Important:** Be careful to seat the mounting post on the fan shroud into the socket at the radiator left tank. Be sure to slip the tab at the bottom edge of the shroud into the retaining clip near the center of the radiator.

5. Secure the shroud to the top of the radiator with the mounting bolts.

### Tighten

Tighten the fan assembly mounting bolts to 4 N•m (35 lb•in).

6. Connect the cooling fan electrical connector.
7. Connect the negative battery cable.

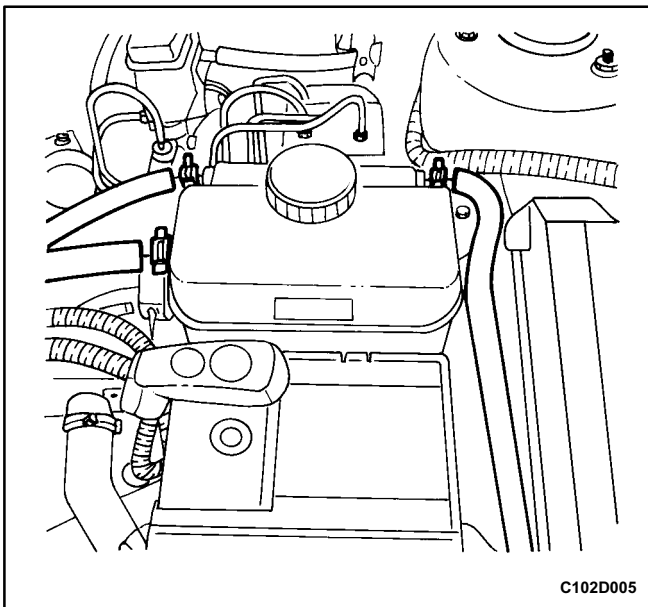

## SURGE TANK

### Removal Procedure

**Caution:** To prevent personal injury, do not remove the surge tank cap while the engine and the radiator are hot, because the heat causes the system to re-main under pressure. Scalding fluid and steam may be blown out under pressure.

1. Drain the engine coolant to below the level of the surge tank.
2. Loosen the return hose clamp and disconnect the re-return hose from the top of the surge tank.
3. Loosen the throttle body hose clamp and disconnect the throttle body hose from the top of the surge tank.
4. Loosen the feed hose clamp and disconnect the feed hose from the bottom of the surge tank.
5. Remove the surge tank attaching bolt.
6. Remove the surge tank from the support mount.
7. Clean the inside and the outside of the surge tank and the surge tank cap with soap and water.
8. Rinse the surge tank and the cap thoroughly.

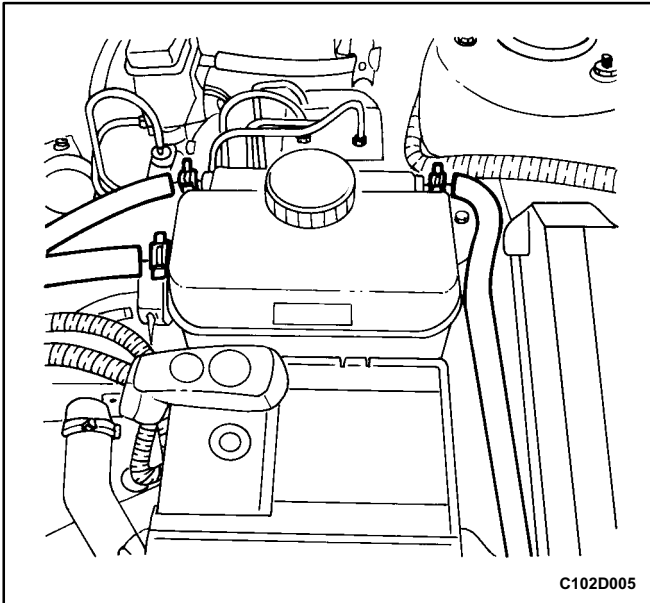

C102D005

### Installation Procedure

1. Install the surge tank to the support mount.
2. Secure the surge tank with the attaching bolt.

### Tighten

Tighten the surge tank attaching bolt to 4 N•m (35 lb•in).

3. Connect the return hose and the throttle body hose to the top of the surge tank.
4. Connect the feed hose to the bottom of the surge tank.
5. Secure the return hose, the throttle body hose, and the feed hose to the surge tank with the hose clamps.
6. Fill the surge tank with the coolant to the center ridge, or to the MAX mark.

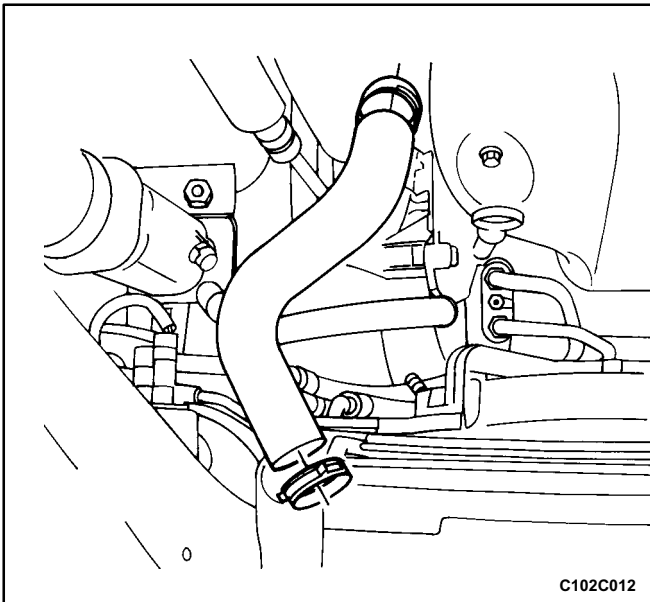

C102C012

## RADIATOR

### Removal Procedure

1. Disconnect the negative battery cable.
2. Drain the engine cooling system. Refer to "Draining and Refilling the Cooling System" in this section.
3. Remove the main and the auxiliary cooling fans. Refer to "Electric Cooling Fan - Main or Auxiliary" in this section.
4. Remove the lower radiator hose clamp.
5. Disconnect the lower radiator hose from the radiator.
6. Remove the upper radiator hose clamp.
7. Disconnect the upper radiator hose from the radiator.
8. Remove the hose clamp from the surge tank hose at the radiator.
9. Disconnect the surge tank hose from the radiator.
10. Disconnect the transaxle fluid cooler pipes from the lower radiator tank, if equipped.
11. Remove the bolt and the transaxle fluid cooler pipe support clamp from the radiator.
12. Remove the left upper radiator retaining bolt.
13. Remove the left upper radiator retaining bracket.

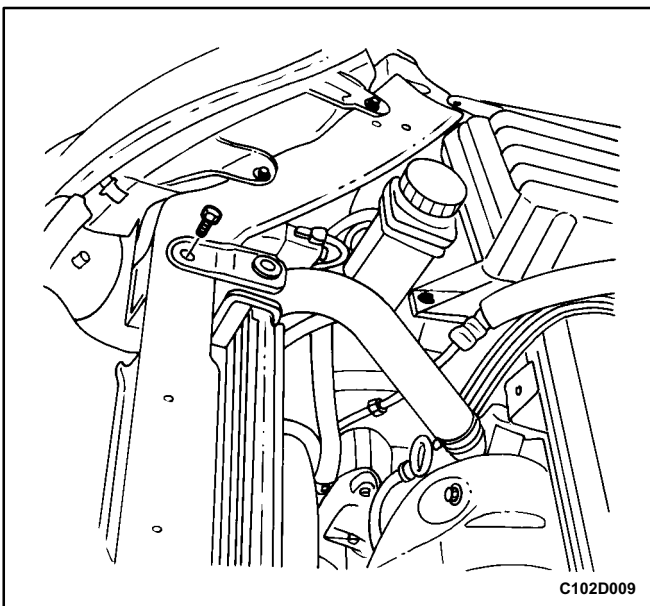

C102D009

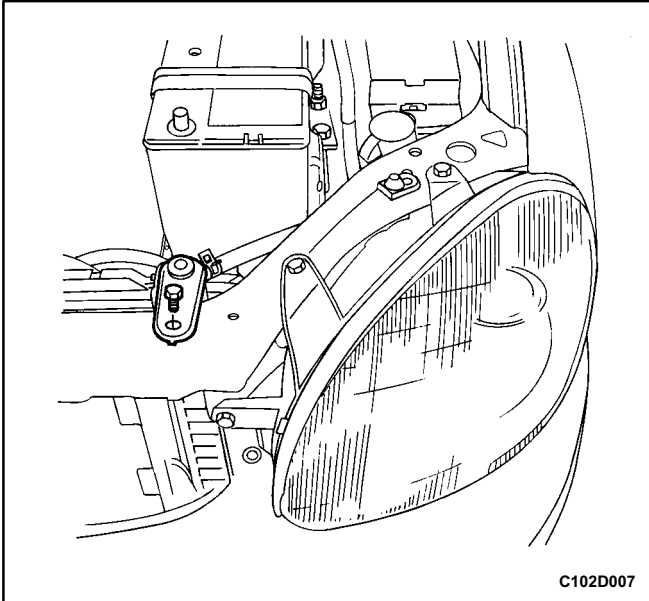

C102D007

14. Remove the right upper radiator retaining bolt.
15. Remove the right upper radiator retaining bracket.
16. Remove the radiator from the vehicle.

**Important:** The radiator still contains a substantial amount of coolant. Drain the remainder of the coolant from the radiator into a drain pan.

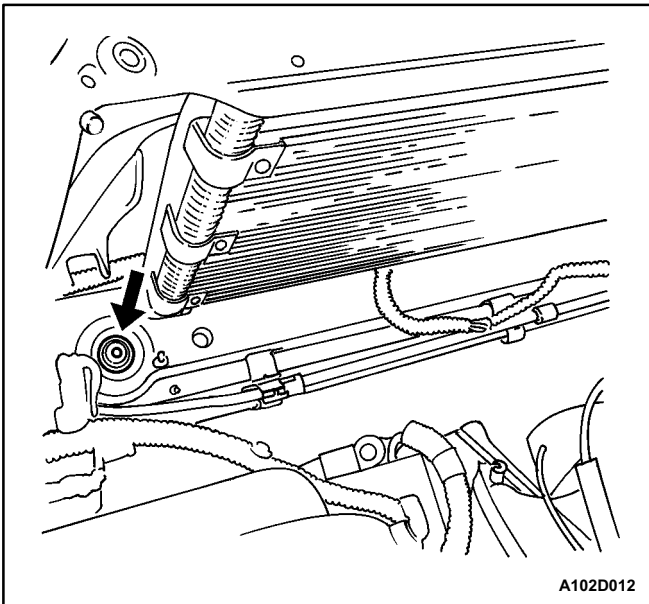

A102D012

### Installation Procedure

1. Set the radiator into place in the vehicle with the radiator bottom posts in the rubber shock bumpers.

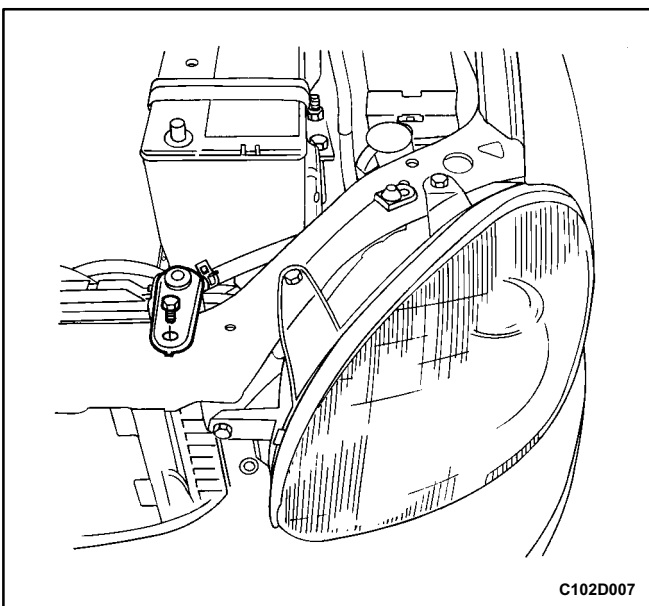

C102D007

2. Position the radiator retainers in place.
3. Install the right upper radiator retainer bracket.
4. Install the right upper radiator retaining bolt.

### Tighten

Tighten the right upper radiator retaining bolt to 4 N•m (35 lb•in).

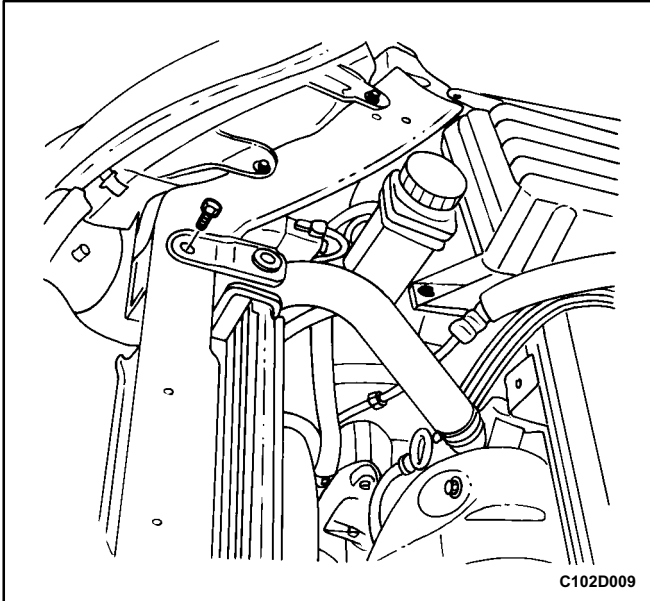

5. Install the left upper radiator retaining bracket.
6. Install the left upper radiator retaining bolt.

### Tighten

Tighten the left upper radiator retaining bolt to 4 N•m (35 lb•in).

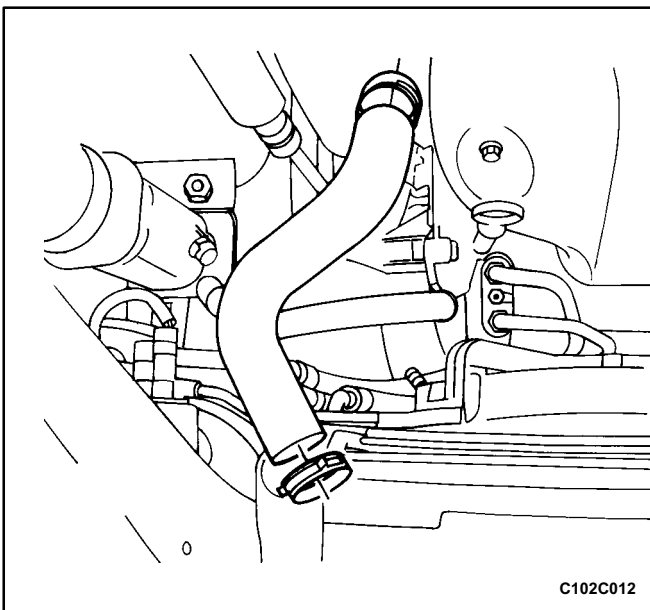

7. Connect the transaxle fluid cooler pipes to the lower radiator tank, if equipped.
8. Install the transaxle fluid cooler pipe and support clamp to the radiator with a bolt.

### Tighten

Tighten the transaxle fluid cooler pipe bolt to 22 N•m (16 lb•ft).

9. Connect the surge tank hose to the radiator.
10. Secure the surge tank hose with a hose clamp.
11. Connect the upper radiator hose and the lower radiator hose to the radiator.
12. Secure each hose with a hose clamp.
13. Install the main and the auxiliary cooling fans. Refer to "Electric Cooling Fan - Main or Auxiliary" in this section.
14. Refill the engine cooling system. Refer to "Draining and Refilling the Cooling System" in this section.
15. Connect the negative battery cable.

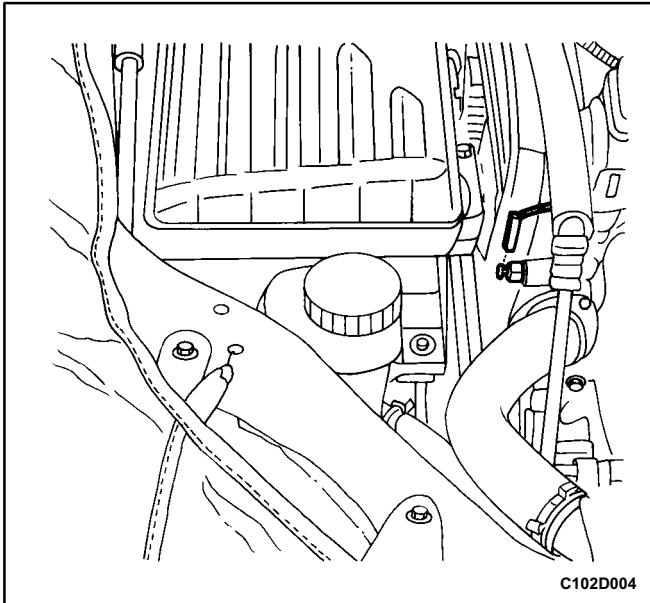

## COOLANT TEMPERATURE SENSOR SOHC

### Removal Procedure

1. Disconnect the negative battery cable.
2. Drain the coolant to a level below the coolant temperature sensor.
3. Disconnect the electrical connector from the coolant temperature sensor.
4. Remove the temperature sensor from the intake manifold.

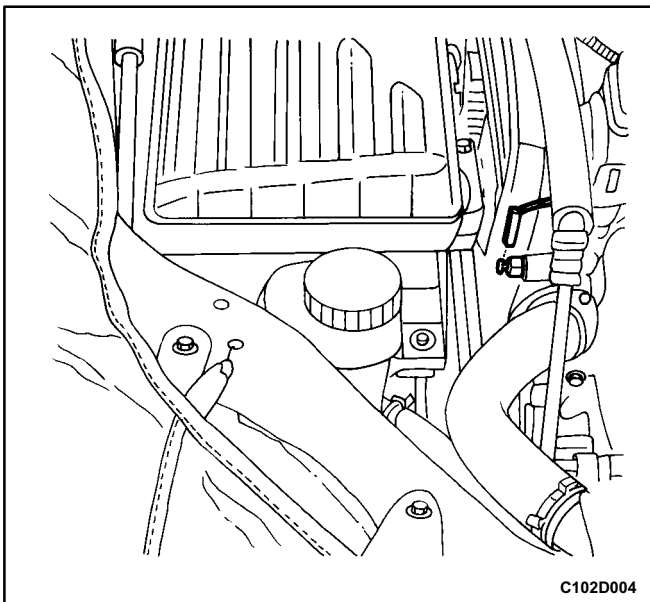

### Installation Procedure

1. Install the coolant temperature sensor into the threaded hole in the intake manifold.

### Tighten

Tighten the coolant temperature sensor to 20 N•m (15 lb•ft).

2. Connect the electrical connector to the coolant temperature sensor.
3. Refill the engine cooling system. Refer to "Draining and Refilling the Cooling System" in this section.
4. Connect the negative battery cable.

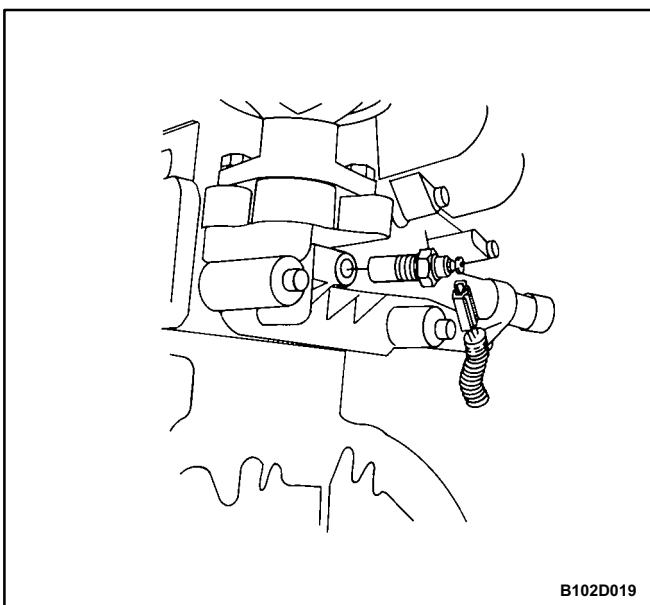

## DOHC

### Removal Procedure

1. Disconnect the negative battery cable.
2. Drain the coolant to a level below the coolant temperature sensor.
3. Disconnect the electrical connector from the coolant temperature sensor.
4. Remove the temperature sensor from the exhaust gas recirculation (EGR) valve mounting adapter.

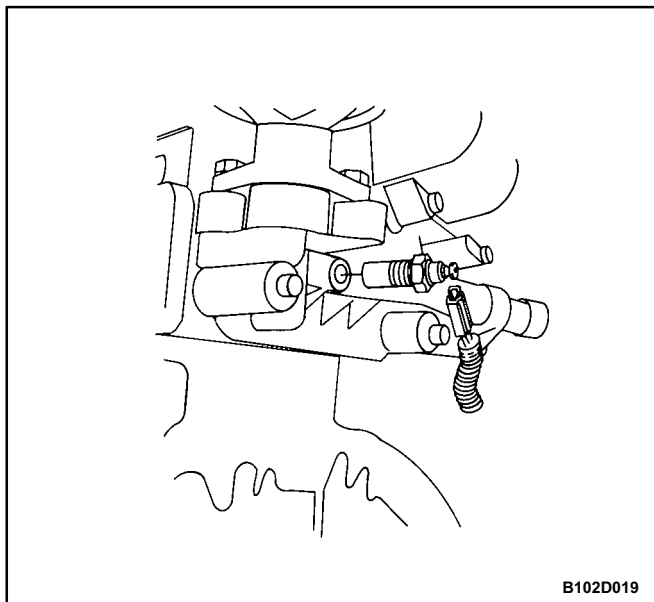

### Installation Procedure

1. Install the coolant temperature sensor into the threaded hole in the EGR valve mounting adapter.

#### Tighten

Tighten the coolant temperature sensor to 20 N•m (15 lb•ft).

2. Connect the electrical connector to the coolant temperature sensor.
3. Refill the engine cooling system. Refer to "Draining and Refilling the Cooling System" in this section.
4. Connect the negative battery cable.

# GENERAL DESCRIPTION AND SYSTEM OPERATION

## GENERAL DESCRIPTION

The cooling system maintains the engine temperature at an efficient level during all engine operating conditions. When the engine is cold, the cooling system cools the engine slowly or not at all. This slow cooling of the engine allows the engine to warm up quickly.

The cooling system includes a radiator and recovery subsystem, cooling fans, a thermostat and housing, a coolant pump, and a coolant pump drive belt. The timing belt drives the coolant pump.

All components must function properly in order for the cooling system to operate. The coolant pump draws the coolant from the radiator. The coolant then circulates through water jackets in the engine block, the intake manifold, and the cylinder head. When the coolant reaches the operating temperature of the thermostat, the thermostat opens. The coolant then goes back to the radiator where it cools.

This system directs some coolant through the hoses to the heater core. This provides for heating and defrosting. The surge tank is connected to the radiator to re-cover the coolant displaced by expansion from the high temperatures. The surge tank maintains the correct coolant level.

The cooling system for this vehicle has no radiator cap or filler neck. The coolant is added to the cooling system through the surge tank.

## RADIATOR

This vehicle has a lightweight tube-and-fin aluminum radiator. Plastic tanks are mounted on the right and the left sides of the radiator core.

On vehicles equipped with automatic transaxles, the transaxle fluid cooler lines run through the left radiator tank. A radiator drain plug is on this radiator.

To drain the cooling system, open the drain plug.

## SURGE TANK

The surge tank is a transparent plastic reservoir, similar to the windshield washer reservoir.

The surge tank is connected to the radiator by a hose and to the engine cooling system by another hose. As the vehicle is driven, the engine coolant heats and expands. The portion of the engine coolant displaced by this expansion flows from the radiator and the engine into the surge tank. The air trapped in the radiator and the engine is degassed into the surge tank.

When the engine stops, the engine coolant cools and contracts. The displaced engine coolant is then drawn back into the radiator and the engine. This keeps the radiator filled with the coolant to the desired level at all times and increases the cooling efficiency.

Maintain the coolant level between the MIN and the MAX marks on the surge tank when the system is cold.

## COOLANT PUMP

The belt-driven centrifugal coolant pump consists of an impeller, a drive shaft, and a belt pulley. The coolant pump is mounted on the front of the transverse-mounted engine, and is driven by the timing belt.

The impeller is supported by a completely sealed bearing.

The coolant pump is serviced as an assembly and, therefore, cannot be disassembled.

## THERMOSTAT

A wax pellet-type thermostat controls the flow of the engine coolant through the engine cooling system. The thermostat is mounted in the thermostat housing to the front of the cylinder head.

The thermostat stops the flow of the engine coolant from the engine to the radiator in order to provide faster warm-up, and to regulate the coolant temperature. The thermostat remains closed while the engine coolant is cold, preventing circulation of the engine coolant through the radiator. At this point, the engine coolant is allowed to circulate only throughout the heater core to warm it quickly and evenly.

As the engine warms, the thermostat opens. This allows the engine coolant to flow through the radiator where the heat is dissipated. This opening and closing of the thermostat permits enough engine coolant to enter the radiator to keep the engine within proper engine temperature operating limits.

The wax pellet in the thermostat is hermetically sealed in a metal case. The wax element of the thermostat expands when it is heated and contracts when it is cooled.

As the vehicle is driven and the engine warms, the engine coolant temperature increases. When the engine coolant reaches a specified temperature, the wax pellet element in the thermostat expands and exerts pressure against the metal case, forcing the valve open. This allows the engine coolant to flow through the engine cooling system and cool the engine.

As the wax pellet cools, the contraction allows a spring to close the valve.

The thermostat begins to open at 87°C (189°F) and is fully open at 102°C (226°F). The thermostat closes at 86°C (187°F).

## ELECTRIC COOLING FAN

**Caution: Keep hands, tools, and clothing away from the engine cooling fans to help prevent personal injury. This fan is electric and can turn on whether or not the engine is running.**

**Caution:** *If a fan blade is bent or damaged in any way, no attempt should be made to repair or reuse the damaged part. A bent or damaged fan assembly should always be replaced with a new one to pre-vent possible injury.*

The cooling fans are mounted behind the radiator in the engine compartment. The electric cooling fans increase the flow of air across the radiator fins and across the condenser on air condition (A/C) equipped vehicles. This helps to speed cooling when the vehicle is at idle or moving at low speeds.

All models have two fans. The main fan is 300 mm (11.8 inches) in diameter with five blades to aid the air flow through the radiator and the condenser. An electric motor attached to the radiator support drives the fan. The auxiliary fan is 300 mm (11.8 inches) in diameter.

- The cooling fans are actuated by the electronic control module (ECM) using a low speed cooling fan relay and a high speed cooling fan relay and a series/parallel cooling fan relay.
- The ECM will turn the cooling fans on at low speed when the coolant temperature reaches 93°C (199°F) and at high speed when the coolant temperature reaches 97°C (207°F).
- The ECM will change the cooling fans from high speed to low speed at 94°C (201°F) and will turn the cooling fans off at 90°C (194°F).

### COOLANT TEMPERATURE SENSOR

The coolant temperature sensor (CTS) uses a thermistor to control the signal voltage to the electronic control module (ECM).

### ENGINE COOLANT TEMPERATURE SENSOR

The engine coolant temperature sensor controls the instrument panel temperature indicator. The engine coolant temperature sensor is located on the intake manifold near the throttle body on an SOHC engine, and on the cylinder head under the intake manifold on a DOHC engine.

### ENGINE BLOCK HEATER

The vehicle is designed to accept an engine block heater. The engine block heater helps warm the engine for improved cold weather starting. It can also help reduce fuel consumption when a cold engine is warming up.

The engine block heater utilizes an existing expansion plug for installation and is located under the intake manifold.

Contact your Daewoo dealer for further information or installation.